

# INSTRUCTIONS FOR ORDERING PARTS

All service parts should be ordered through your authorized H&S dealer. He will be able to give you faster service if you will provide them with the following:

1. Model & Serial Number - Both can be located on the side of the center bearing post above jack mount.
2. All references to left or right apply to the machine as viewed from the rear.
3. Parts should not be ordered from illustration only. Please order complete part number.
4. If your dealer has to order parts - give shipping instructions:

VIA truck - large pieces (please specify local truck lines)

VIA United Parcel Service (include full address)

<b>H&amp;S MFG. CO. INC.</b>	
MARSHFIELD, WIS.	
MOD. NO.	<input type="text"/>
SER. NO.	<input type="text"/>
DESCR.	<input type="text"/>

PLEASE RECORD NUMBERS FOR YOUR UNIT FOR QUICK REFERENCE

## ABOUT IMPROVEMENTS

H&S IS CONTINUALLY STRIVING TO IMPROVE IT'S PRODUCTS

We must therefore, reserve the right to make improvements or changes whenever it becomes practical to do so, without incurring any obligation to make changes or additions to the equipment previously sold.

FIGURE 1

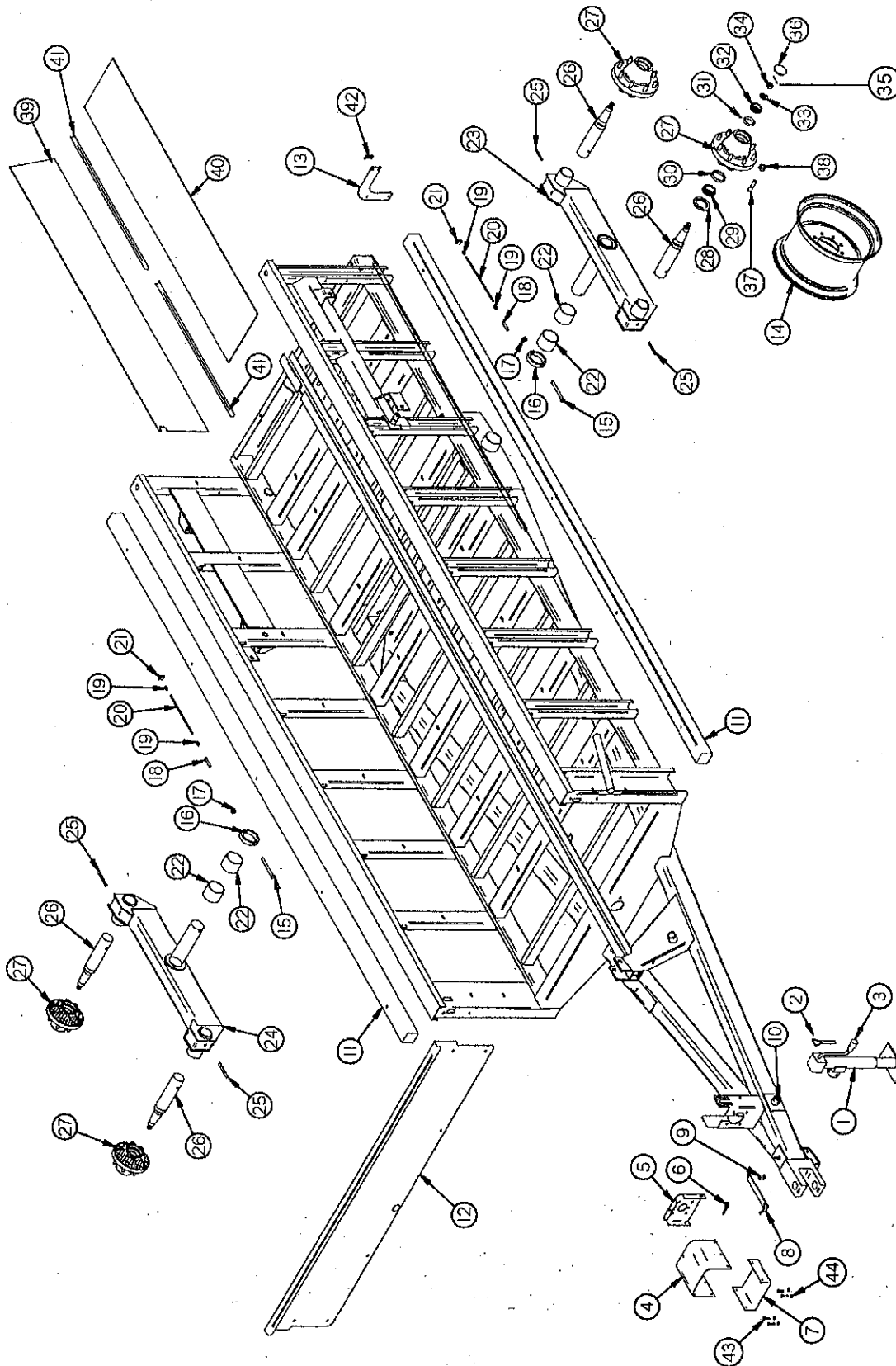
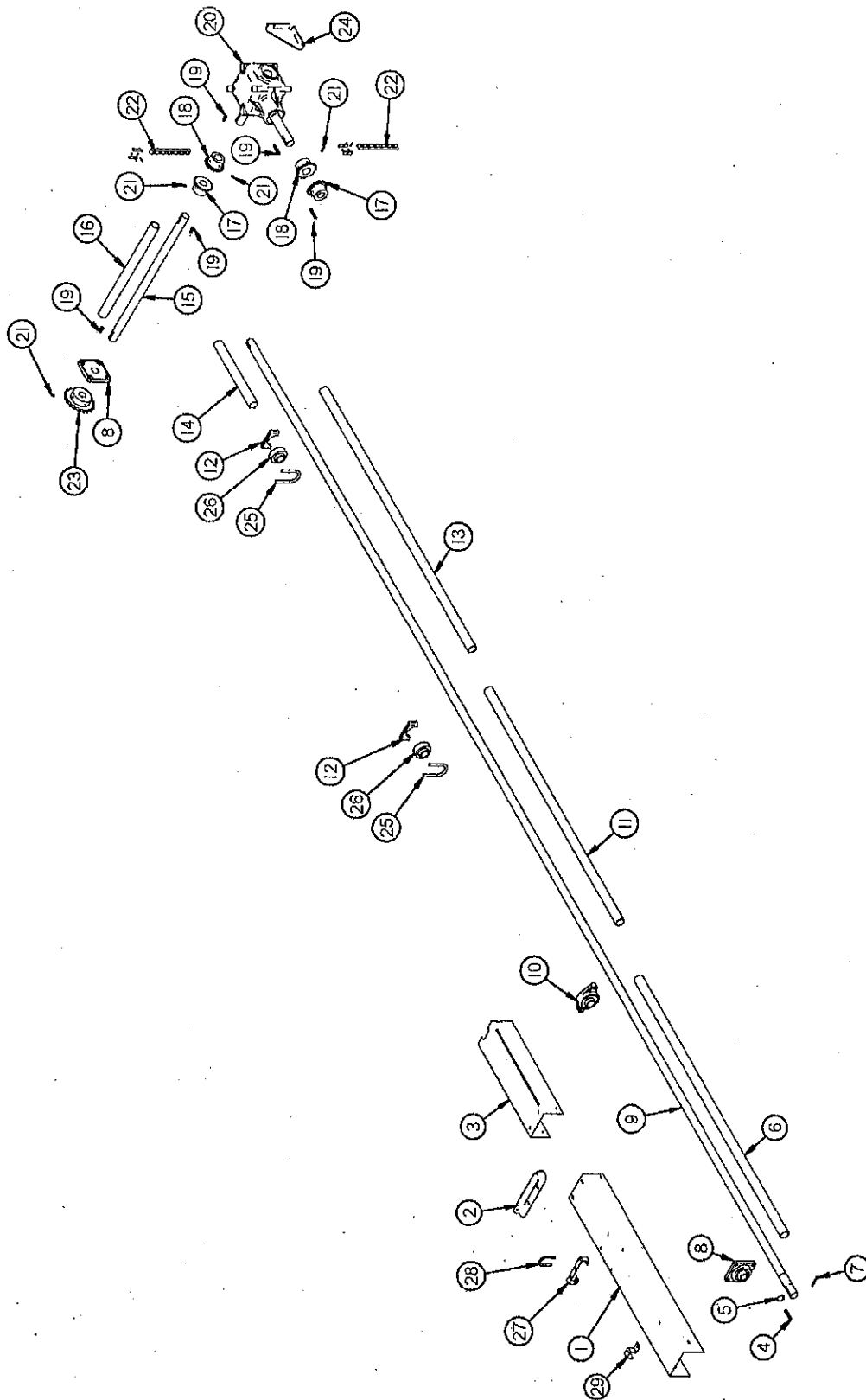

**FIGURE 1**  
**H&S HP425 & HP550 SPREADERS**  
**FRAME ASSEMBLY**

ITEM	HP425	HP550	DESCRIPTION
1.	27N14	"	Jack
2.	12N13	"	Jack Pin & Chain
3.	12N12	"	Jack Handle
4.	16SV329	"	PTO Shield
5.	42N1	"	Shield Mount
6.	X97	"	Hair Pin
7.	16SV327	"	PTO Shield Bottom
8.	42N2	"	PTO Holder
9.	42N3	"	Spring
10.	12N14	"	Jack Mount
11.	42N4	"	Wood Rail
12.	42N5	55N1	Front Panel
13.	42N43	"	SMV Bracket
14.	16SV89	-	Wheel 13.5 x 22.5 (8 Bolt)
*	-	60N15	Wheel 13.5 x 22.5 (10 Bolt)
*	42N138	-	Tire (385 x 22.5 Truck)
*	-	16SV88	Tire (425 x 22.5 Truck)
15.	BFR405	-	1/2" x 5-1/2" Bolt GR. 5
*	-	16SV77	1/2" x 6" Bolt GR. 5
16.	45N35	16SV214	Collar For Axle
17.	9S17	"	1/2" Lock Nut
18.	45N57	"	Grease Line Adapter
19.	S47	"	Grease Fitting
20.	42N41	"	Grease Line
21.	16V9	"	Grease Bracket
22.	45N36	16SV75	Bushing For Tandem Axle
23.	42N6	55N2	Tandem Axle Left
24.	42N7	55N3	Tandem Axle Right
25.	31N4	"	Roll Pin
26.	33SV40	66N15	Spindle
27.	33SV45	60N8	Hub
28.	33SV42	60N5	Seal
29.	33SV43	60N7	Inner Bearing
30.	33SV44	60N6	Inner Race
31.	RG169	60N10	Outer Race
32.	RG170	60N9	Outer Bearing
33.	33SV95	60N2	Washer
34.	RG17	60N3	Spindle Nut
35.	33SV46	60N4	Cotter Pin
36.	RG171	60N11	Hub Cap
37.	33SV41	HP60N13	Stud
38.	RG72	60N14	Lug Nut
39.	42N8	55N4	Side Poly Right
*	42N9	55N5	Side Poly Left
40.	42N10	"	Floor Poly Right
*	42N11	"	Floor Poly Left
41.	42N12	"	Poly Side Angle
42.	F97	"	SMV Holder
43.	42N97	"	5/16" x 2" Shear Bolt GR.5 (1000 RPM)
*	42N98	-	5/16" x 2" Shear Bolt GR. 8 (540 RPM)
44.	D81	"	Lock Nut

**NOTE: \* (MEANS NOT SHOWN)**  
**- (MEANS NOT USED ON THIS MODEL)**  
**" (MEANS SAME AS PREVIOUS PART NO.)**

FIGURE 2



**FIGURE 2**  
**H&S HP425 & HP550 SPREADERS**  
**BEATER DRIVE TRAIN**

ITEM	HP425	HP550	DESCRIPTION
1.	42N13	"	Input Shaft Shield
2.	42N14	"	Input Shield Angle
3.	42N15	"	Input Shield Back
4.	S138	"	3/8" x 2-3/8" Key
5.	12V62	"	Snap Ring
6.	42N16	"	Input PVC Shield
7.	16SV379	"	3/8" x 2-1/2" Roll Pin
8.	12V67	"	Bearing
9.	42N17	"	Input Shaft
10.	42N18	"	Bearing
11.	42N19	"	Drive Shaft Center PVC Shield
12.	42N137	"	Bearing Saddle
13.	42N20	"	Drive Shaft Middle PVC Shield
14.	42N21	"	Drive Shaft Back PVC Shield
15.	42N22	"	Cross Shaft
16.	42N23	"	Cross Shaft PVC Shield
17.	42N24	"	Sprocket 50-B-20 1-1/2" Bore
18.	42N25	"	Sprocket 50-B-20 1-1/2" Bore
19.	PB136	"	3/8" x 2" Key
20.	42N26	"	Gearbox
21.	G83	"	Set Screw
22.	42N27	"	Connector Chain #50 x 20 Pitches
23.	12V104	"	20 T Sprocket
24.	42N49	"	Gearbox Gusset
25.	42N99	"	3/8" U-Bolt
26.	42N100	"	Bearing
27.	42N101	"	Hose Holder
28.	42N102	"	5/16" x 2" ID U-Bolt
29.	HE14	-	Small Pipe Bracket

**NOTE: " (MEANS SAME AS PREVIOUS PART NO.)**

**- (MEANS NOT USED ON THIS MODEL)**

FIGURE 3

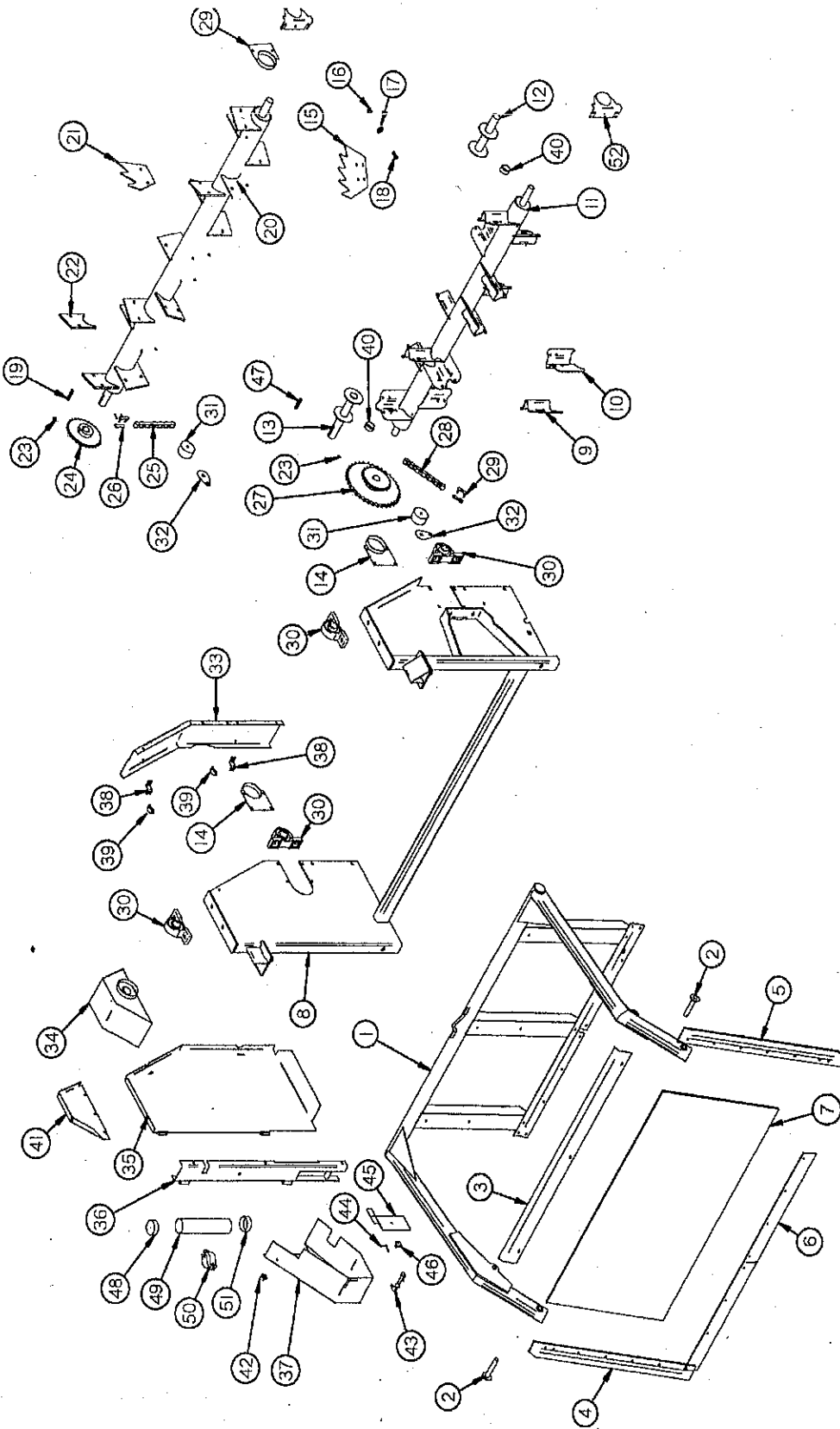
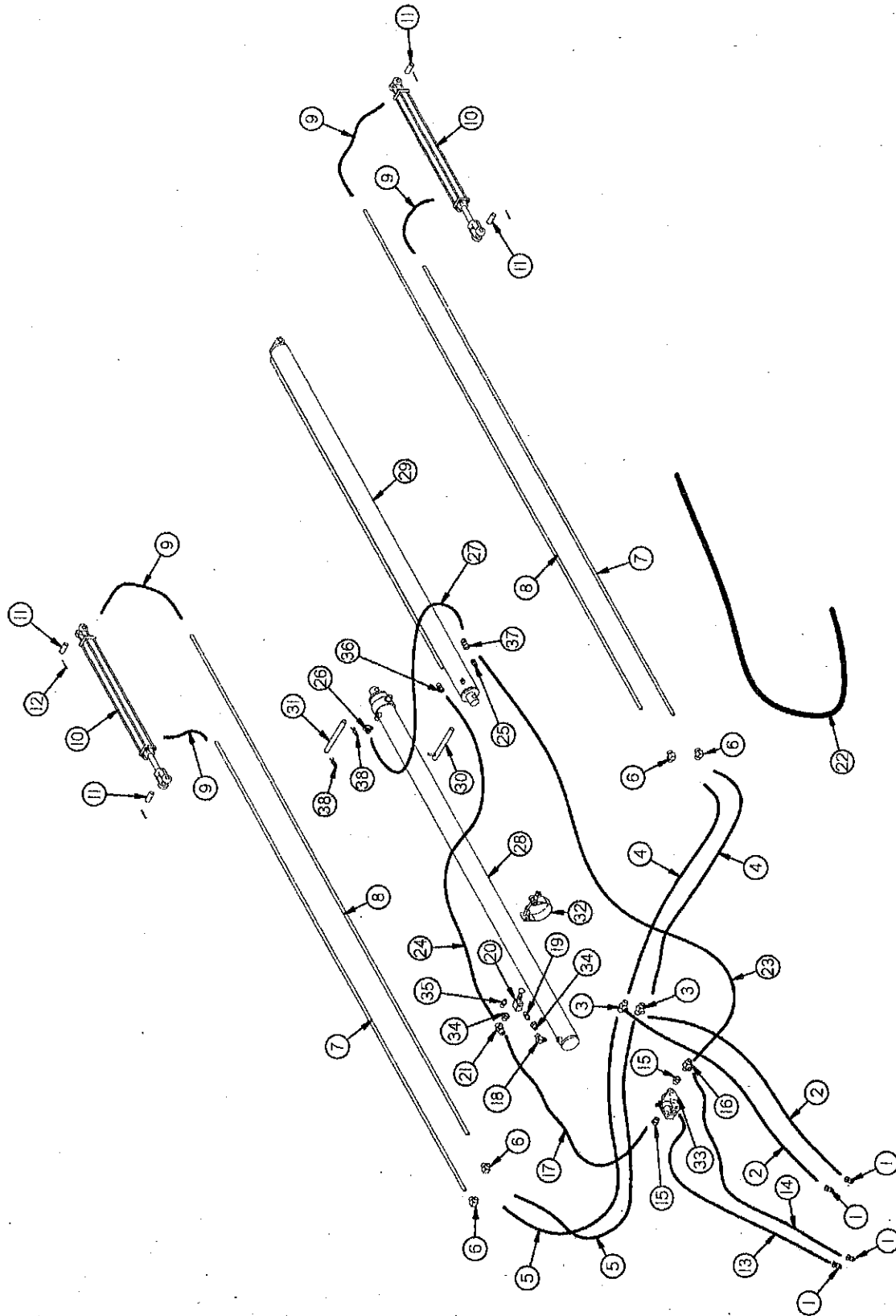

**FIGURE 3**  
**H&S HP425 & HP550 SPREADERS**  
**ENDGATE & BEATER**

ITEM	HP425	HP550	DESCRIPTION
1.	42N28	55N9	Endgate
2.	42N29	55N10	Hinge Pin
3.	42N30	55N11	Endgate Poly Holdown
4.	42N31	55N12	Endgate Rubber Right
5.	42N32	55N13	Endgate Rubber Left
6.	42N33	55N14	Endgate Rubber
7.	42N34	55N15	Endgate Poly
8.	42N35	55N16	Beater Panel
9.	42N36	"	Blade Holder Right
10.	42N37	"	Blade Holder Left
11.	42N38	"	Beater
12.	56N69	"	Beater Stub Shaft
13.	42N39	"	Beater Drive Shaft
14.	42N40	"	Beater Slot Filler
15.	23N277	"	Beater Blade
16.	R11	"	1/2" Lock Nut
17.	R35	"	Lock Washer
18.	R10	"	1/2" x 1-1/4" Beater Blade Bolt GR. 5
19.	S436	-	3/8" x 1-1/2" Key
*	-	PB136	3/8" x 2" Key
20.	42N42	42N38	Second Beater
21.	45N27	23N277	Second Beater Blade
22.	45N43	-	Blade Holder
*	-	42N36	Blade Holder Right
*	-	42N37	Blade Holder Left
23.	G83	"	3/8" Set Screw
24.	42N44	-	Second Beater Sprocket 60-B-30
*	-	16SV213	Second Beater Sprocket 80-B-23
25.	42N45	-	Second Beater Chain #60 x 98 Pitches
*	-	55N17	Second Beater Chain #80 x 82 Pitches
26.	F157	D39	Connector Link
27.	42N46	-	Beater Sprocket #80, 20T To #60, 25T (540 RPM)
*	-	55N19	Beater Sprocket #80, 36T To #80, 20T (1000 RPM)
*	42N47	-	Beater Sprocket #80, 36T To #60, 25T (1000 RPM)
28.	16SV34	-	Beater Chain #80 x 79 Pitches (540 RPM)
*	42N48	"	Beater Chain #80 x 88 Pitches (1000 RPM)
29.	-	55N18	Second Beater Slot Filler
30.	16SV72	"	Pillow Block Bearing
31.	42N50	"	Poly Chain Tightener
32.	42N51	"	Tightener Stop
33.	42N52	55N20	Main Panel Right End
34.	42N53	-	Second Beater Anti-Wrap
35.	42N54	55N21	Rear Shield
36.	42N55	55N22	Shield Filler
37.	42N56	"	Cross Shaft Shield
38.	F69	"	Shield Bracket
39.	F56	"	Clip Pin
40.	42N103	"	Beater Spacer
41.	42N104	-	Second Beater Shield
42.	X193	"	Latch Catch Bracket
43.	X192	"	Latch (Rubber)
44.	X195	"	Pin
45.	42N105	"	Back Stake Filler
46.	X194	"	Latch Mounting Bracket
47.	42N141	"	3/8" x 2-1/4" Key
48.	S414	"	Cap
49.	S415	"	Manual Holder Tube
50.	S416	"	Manual Holder Clamp
51.	S418	"	Cap w/Hole

NOTE: \*(MEANS NOT SHOWN)  
 - (MEANS NOT USED ON THIS MODEL)  
 " (MEANS SAME AS PREVIOUS PART NO.)

FIGURE 4



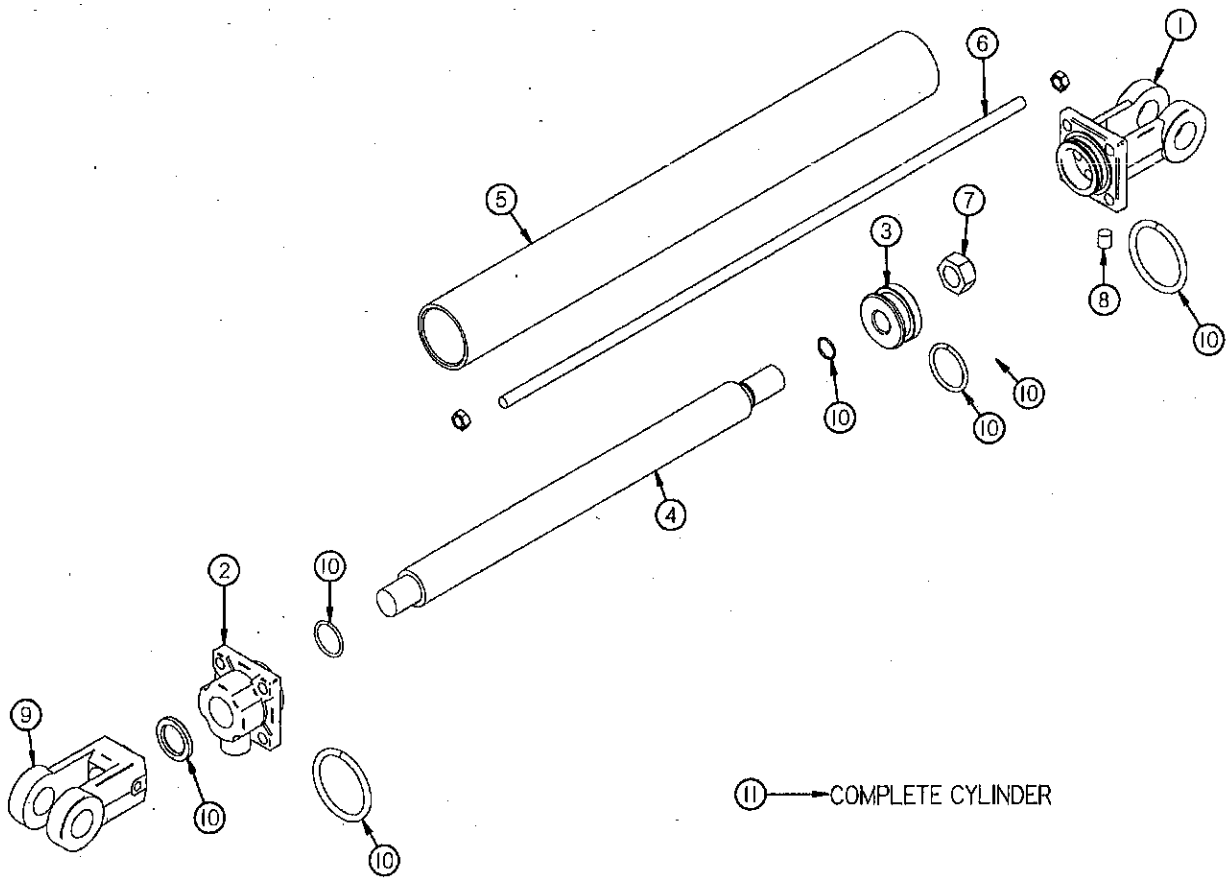

**FIGURE 4**  
**H&S HP425 & HP550 SPREADERS**  
**HYDRAULICS**

ITEM	HP425	HP550	DESCRIPTION
1.	DWM205	"	Quick Coupler Male
2.	12SV25	"	Hydraulic Hose 3/8"x145" (1/2"MPX x 3/8"MPX)
*	-	55N82	Hydraulic Hose 3/8"x155" (1/2"MP x 3/8"MP)
3.	BFR74	"	3/8" Tee
4.	46N40	"	Hydraulic Hose 3/8"x46" (3/8"MPX x 3/8"MP)
5.	BFR287	"	Hydraulic Hose 3/8"x36" (3/8"MPX x 3/8"MP)
6.	HE59	"	3/8" Elbow
7.	42N59	55N23	End Gate Hydraulic Line Short
8.	42N60	55N24	End Gate Hydraulic Line Long
9.	12V19	"	Hydraulic Hose 3/8"x24" (3/8"FP x 3/8"MPX)
10.	45N45	"	Hydraulic Cylinder (2' x 20")
11.	56N141	"	Cylinder Pin
12.	23N108	"	7/32" x 2" Cotter Pin
13.	42N61	"	Hydraulic Hose 3/8"x93" (1/2"MP x 1/2"MP)
*	-	55N6	Hydraulic Hose 1/2"x93" (1/2"MP x 1/2"MP)
14.	42N62	"	Hydraulic Hose 3/8"x95" (3/8"MP x 1/2"MP)
*	-	55N7	Hydraulic Hose 1/2"x95" (1/2"MP x 1/2"MP)
15.	JB82	-	1/2" x 3/8" Bushing
16.	23N116	-	3/8" Service Tee
*	-	LW96	1/2" Service Tee
17.	42N63	-	Hydraulic Hose 3/8"x82" (3/8"MPX x 3/8"MPX 90°)
*	-	55N8	Hydraulic Hose 1/2"x82" (1/2"MPX x 1/2"MPX 90°)
18.	23N234	-	3/8" Street Elbow
*	-	HE58	1/2" Street Elbow
19.	16SV351	"	3/8" Nipple Nut
20.	16SV339	"	Sequence Valve
21.	WM146	-	3/8" Male, Female Tee
*	-	DF8	1/2" Tee
22.	42N64	"	Hose Shield (1-1/2"ID x 73")
23.	42N65	-	Hydraulic Hose 3/8"x158" (3/8"MPX 90° x 3/8"MPX)
*	-	55N29	Hydraulic Hose 1/2"x158" (1/2"MPX 90° x 1/2"MPX)
24.	42N66	-	Hydraulic Hose 3/8"x76" (3/8"MP x 3/8"MP)
*	-	55N30	Hydraulic Hose 1/2"x76" (1/2"MP x 1/2"MP)
25.	42N67	-	3/8" Union Adapter 45°
*	-	55N65	1/2" Union Adapter 45°
26.	DWM110	-	3/8" Union Adapter 90°
*	-	HE58	1/2" Street Elbow
27.	42N68	-	Hydraulic Hose 3/8"x20-1/2" (3/8"MP x 3/8"MPX 90°)
*	-	16SV143	Hydraulic Hose 1/2"x19" (1/2"MP x 1/2"MPX)
28.	42N69	-	Hydraulic Cylinder 3-1/2" x 90" Gimbal Mount
*	-	55N32	Hydraulic Cylinder 4-1/2" x 90" Gimbal Mount
29.	42N70	-	Hydraulic Cylinder 3-1/2" x 90" Trunnion Mount
*	-	55N33	Hydraulic Cylinder 4-1/2" x 90" Trunnion Mount
30.	42N71	55N34	Cylinder Pin
31.	42N72	55N35	Pusher Cylinder Pin
32.	12V70	-	Hose Clamp SAE#88
*	-	55N66	Hose Clamp SAE#104
33.	42N73	"	Flow Control
34.	-	JB82	1/2" To 3/8" Bushing
35.	-	16SV351	3/8" Nipple Nut
36.	DWM233	-	3/8" Union Adapter
*	-	55N70	1/2" Union Adapter
37.	23N116	-	3/8" Service Tee
*	-	WM139	1/2" Male-Female Tee
38.	T144	*	Cylinder Clip Pin

NOTE: \* (MEANS NOT SHOWN)  
 - (MEANS NOT USED ON THIS MODEL)  
 " (MEANS SAME AS PREVIOUS PART NO.)

**FIGURE 5**



**FIGURE 5  
H&S HP425 & HP550 SPREADERS  
HYDRAULIC END GATE CYLINDER**

ITEM	HP425	HP550	DESCRIPTION
1.	23N142A	"	Clevis Cap
2.	23N143A	"	Rod Cap
3.	23N144	"	Piston
4.	45N42	"	Rod
5.	45N43	"	Cylinder Tube
6.	45N44	"	Tie Rod
7.	23N148	"	Piston Nut
8.	23N149	"	Plug
9.	23N150A	"	Rod Clevis
10.	23N151	"	Seal Kit
11	45N45	"	Hydraulic Cylinder

FIGURE 6

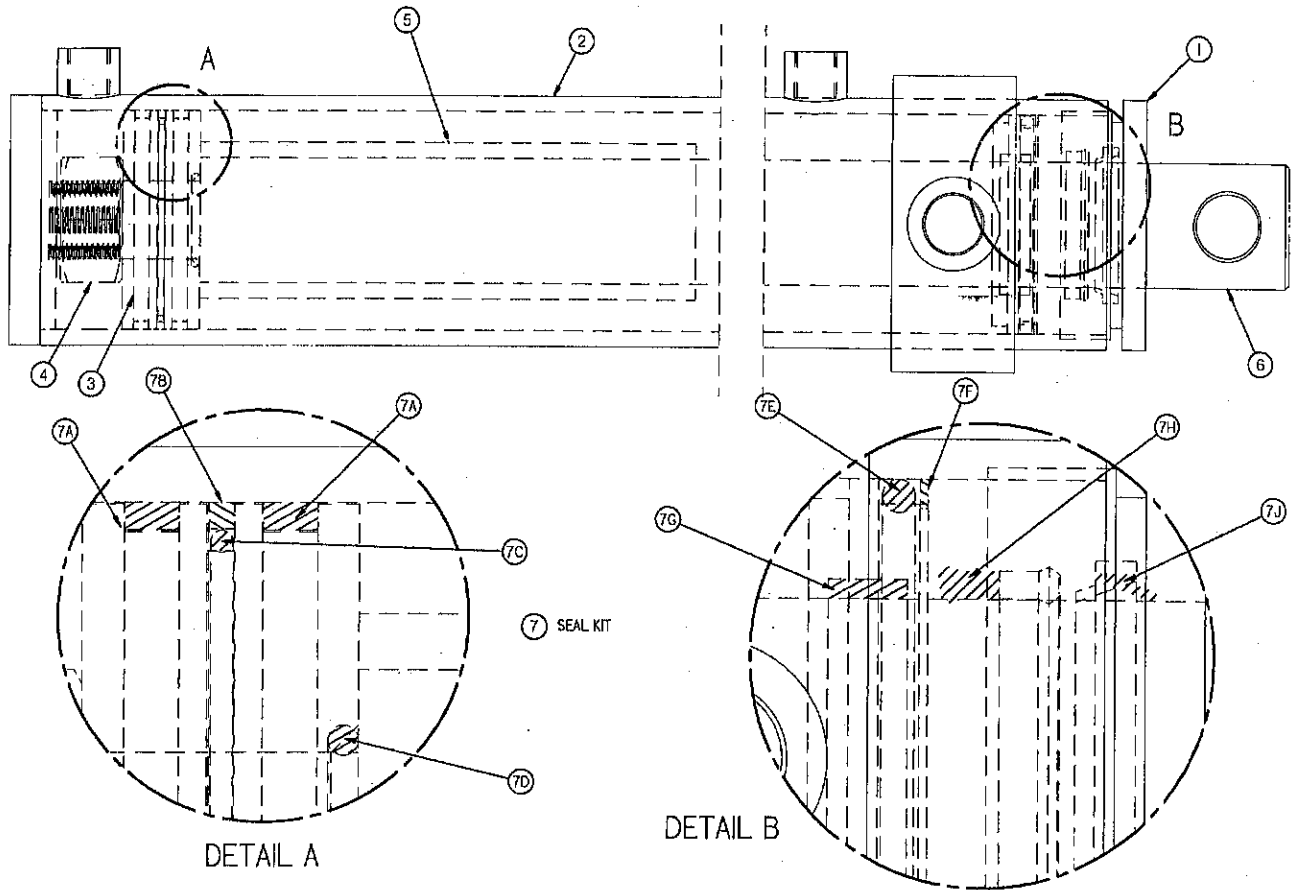

FIGURE 6  
H&S HP425 & HP550 SPREADERS  
HYDRAULIC PUSHER CYLINDER

ITEM	HP425	HP550	DESCRIPTION
1.	42N106	55N36	Internal Head
2.	42N107	55N37	Barrel Assembly (Top Cylinder)
*	42N108	55N38	Barrel Assembly (Bottom Cylinder)
3.	42N109	55N39	Piston
4.	42N110	55N40	Lock Nut
5.	42N111	55N41	Spacer
6.	42N112	55N42	Rod
7.	42N113	55N43	Seal Kit
7A.	"	"	Wear Ring
7B.	"	"	Poly Hone
7C.	"	"	O-Ring
7D.	"	"	O-Ring
7E.	"	"	O-Ring
7F.	"	"	Back-up Ring
7G.	"	"	Wear Ring
7H.	"	"	Loaded U-Cup
7J.	"	"	Rod Wiper
*	42N69	55N32	Complete Cylinder (Top)
*	42N70	55N33	Complete Cylinder (Bottom)

NOTE: \* (MEANS NOT SHOWN)

" (PART NOT SOLD SEPRATELY ONLY COMPLETE KIT)

FIGURE 7

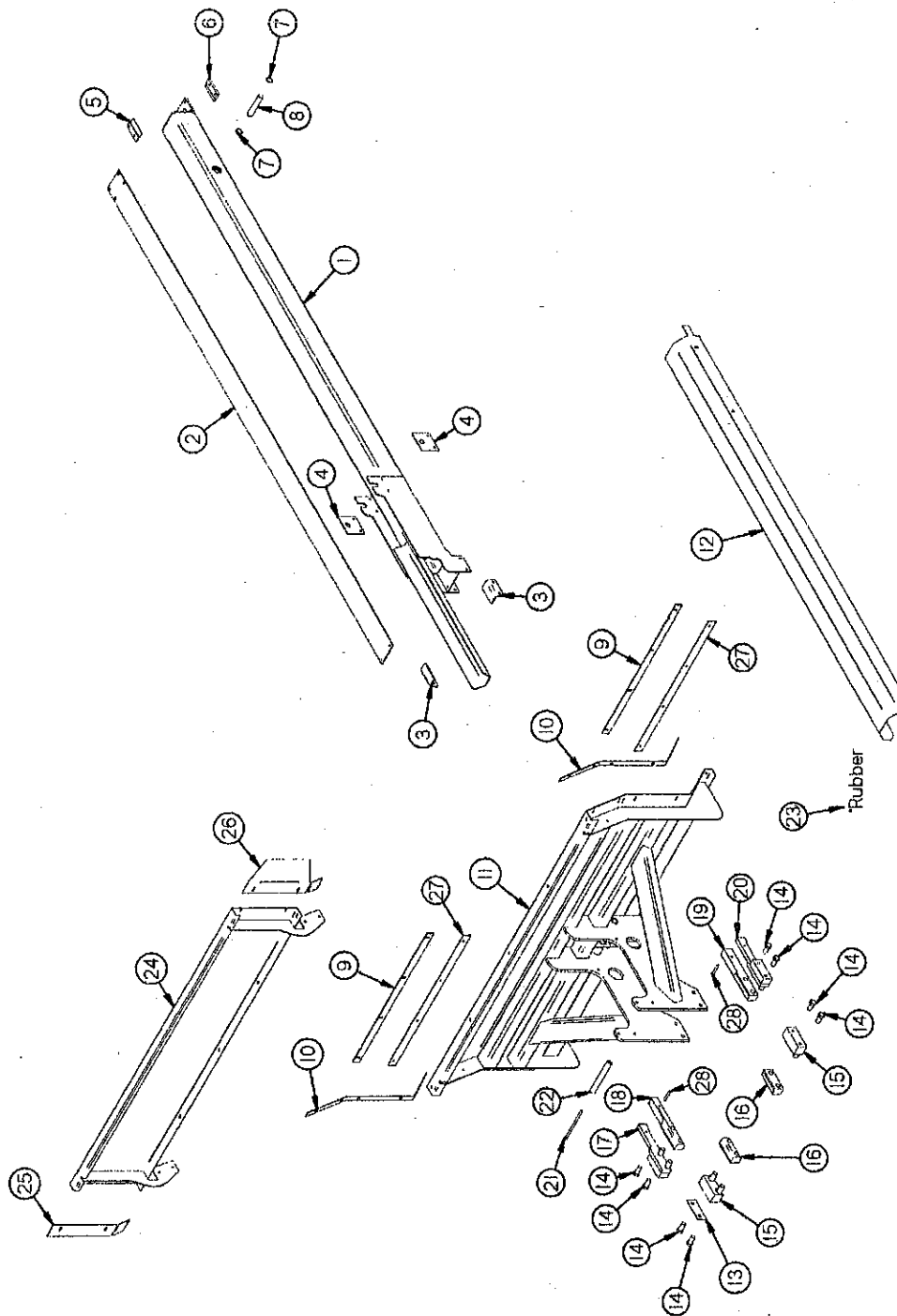

**FIGURE 7**  
**H&S HP425 & HP550 SPREADERS**  
**PUSHER**

ITEM	HP425	HP550	DESCRIPTION
1.	42N74	55N44	Moveable Floor Tube
2.	42N75	55N45	Pusher Tubing Slide
3.	42N76	55N46	Pusher Tube Front Guide
4.	42N77	55N47	Cylinder Retainer
5.	42N78	55N48	End Cap Clamp Right
6.	42N79	55N49	End Cap Clamp Left
7.	3G21	-	1" Snap Ring
*	-	F73	1-1/4" Snap Ring
8.	42N80	55N50	Rear Cylinder Pin
9.	42N81	55N81	Pusher Wiper
10.	42N82	55N25	Pusher Rubber Strap
11.	42N83	55N26	Pusher
12.	42N84	55N51	Cylinder Shield
13.	42N114	-	Pusher Shim (As Required)
14.	50N183	"	5/8" x 1-1/4" Bolt GR. 5
15.	42N85	55N52	Poly Block Spacer
16.	42N86	55N53	Pusher Poly Slide
17.	42N87	55N54	Poly Block Spacer Right
18.	42N88	55N55	Pusher Poly Slide Right
19.	42N89	55N56	Pusher Poly Slide Left
20.	42N90	55N57	Poly Block Spacer Left
21.	A7	-	1/2" x 9-1/2" Bolt GR. 5
*	-	55N58	1/2" x 10-1/2" Bolt GR. 5
22.	42N91	55N59	Pusher Spacer
23.	42N92	55N27	Pusher Rubber Left
*	42N93	55N28	Pusher Rubber Right
24.	42N94	"	Pusher Extension
25.	42N95	"	Extension Wing Right
26.	42N96	"	Extension Wing Left
27.	42N139	55N83	Pusher Bottom Rubber
28.	42N140	16SV379	3/8" Expansion Pin

NOTE: \* (MEANS NOT SHOWN)

- (MEANS NOT USED ON THIS MODEL)

FIGURE 8

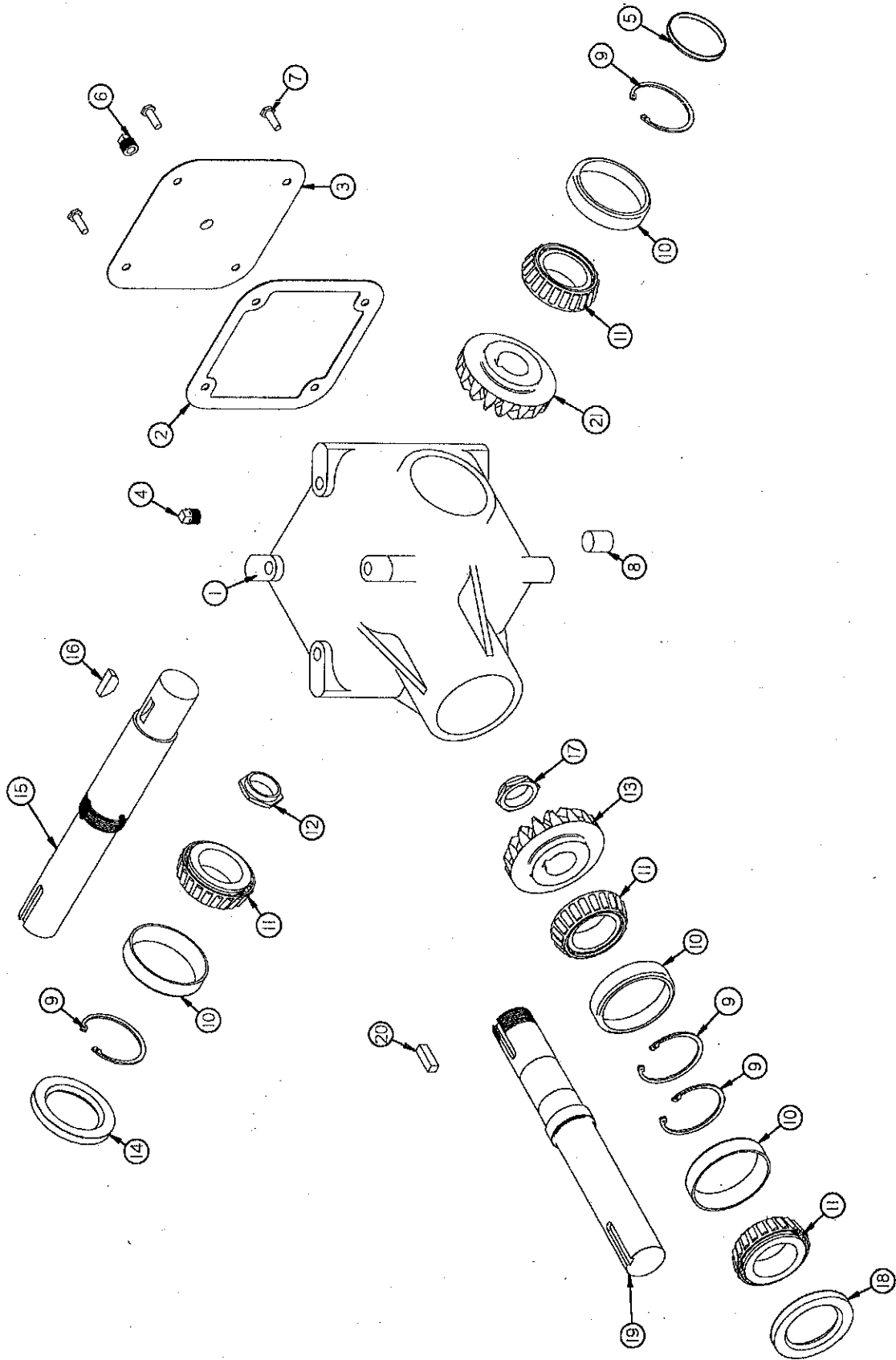
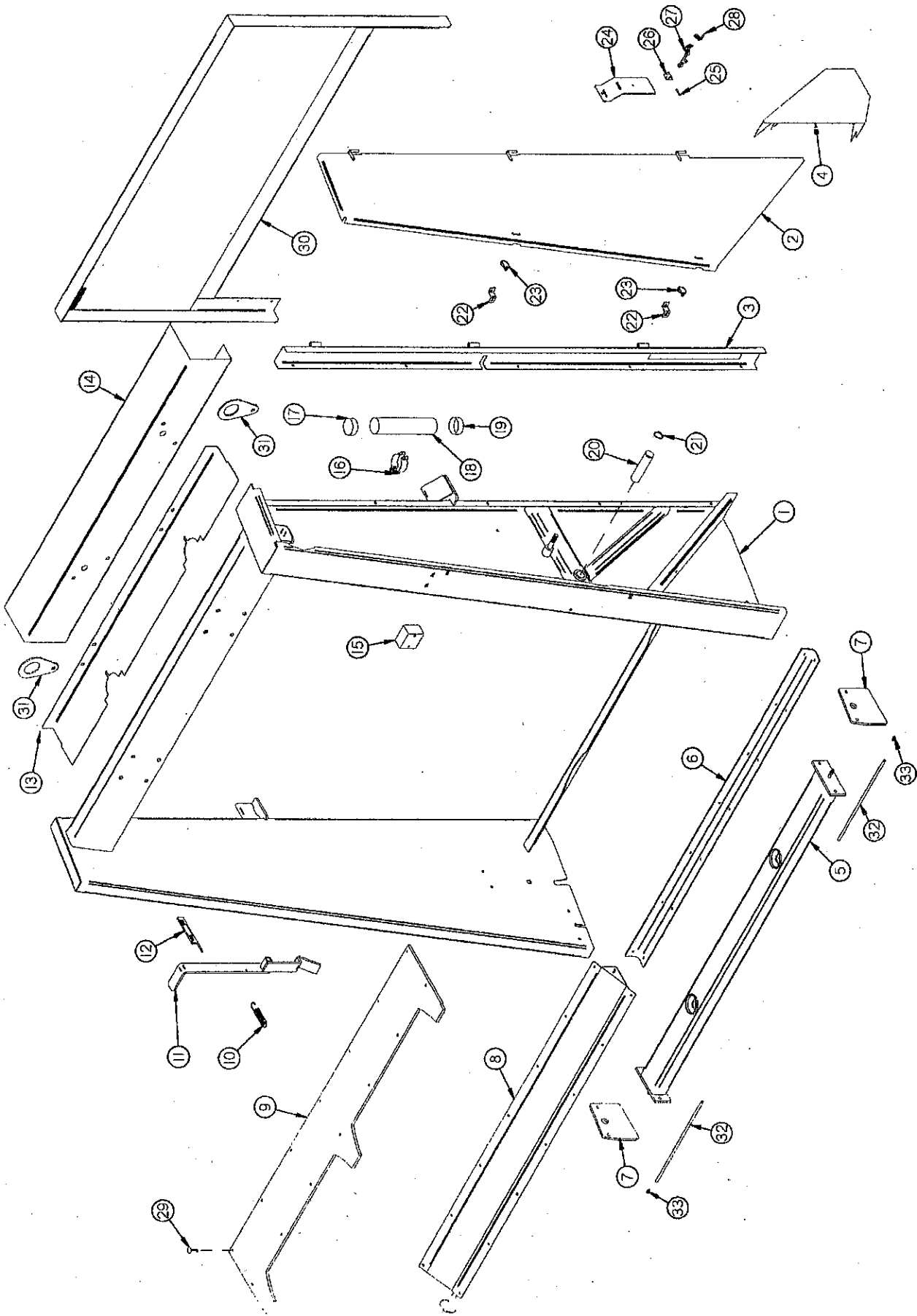

**FIGURE 8**  
**H&S HP425 & HP550 SPREADERS**  
**BEATER GEAR BOX**

ITEM	HP425	HP550	DESCRIPTION
1.	G125	"	Housing
2.	G138	"	Gasket
3.	G126	"	Cover
4.	G144	"	3/8" Vent Plug
5.	G140	"	Cap
6.	G65	"	3/8" Plug - NPT
7.	G56	"	5/16" x 5/8" Cap Screw
8.	G145	"	3/8" Plug
9.	G130	"	Snap Ring
10.	G128	"	Bearing Cup #25520
11.	G129	"	Bearing #25581
12.	G132	"	Stake Nut
13.	G142	"	Bevel Gear 22 Teeth
14.	G136	"	Seal - Output
15.	42N57	"	Output Shaft
16.	G61	"	"E" 1210 Woodruff Key
17.	G133	"	Stake Nut
18.	G137	"	Seal - Input
19.	42N58	"	Input Shaft
20.	G139	"	3/8" x 1-1/2" Hardened Key
21.	G127	"	Bevel Gear 33 Teeth
*	42N26	"	Complete Gear Box

**NOTE \* (MEANS NOT SHOWN)**  
**- (MEANS SAME AS PREVIOUS PART NO.)**

FIGURE 9



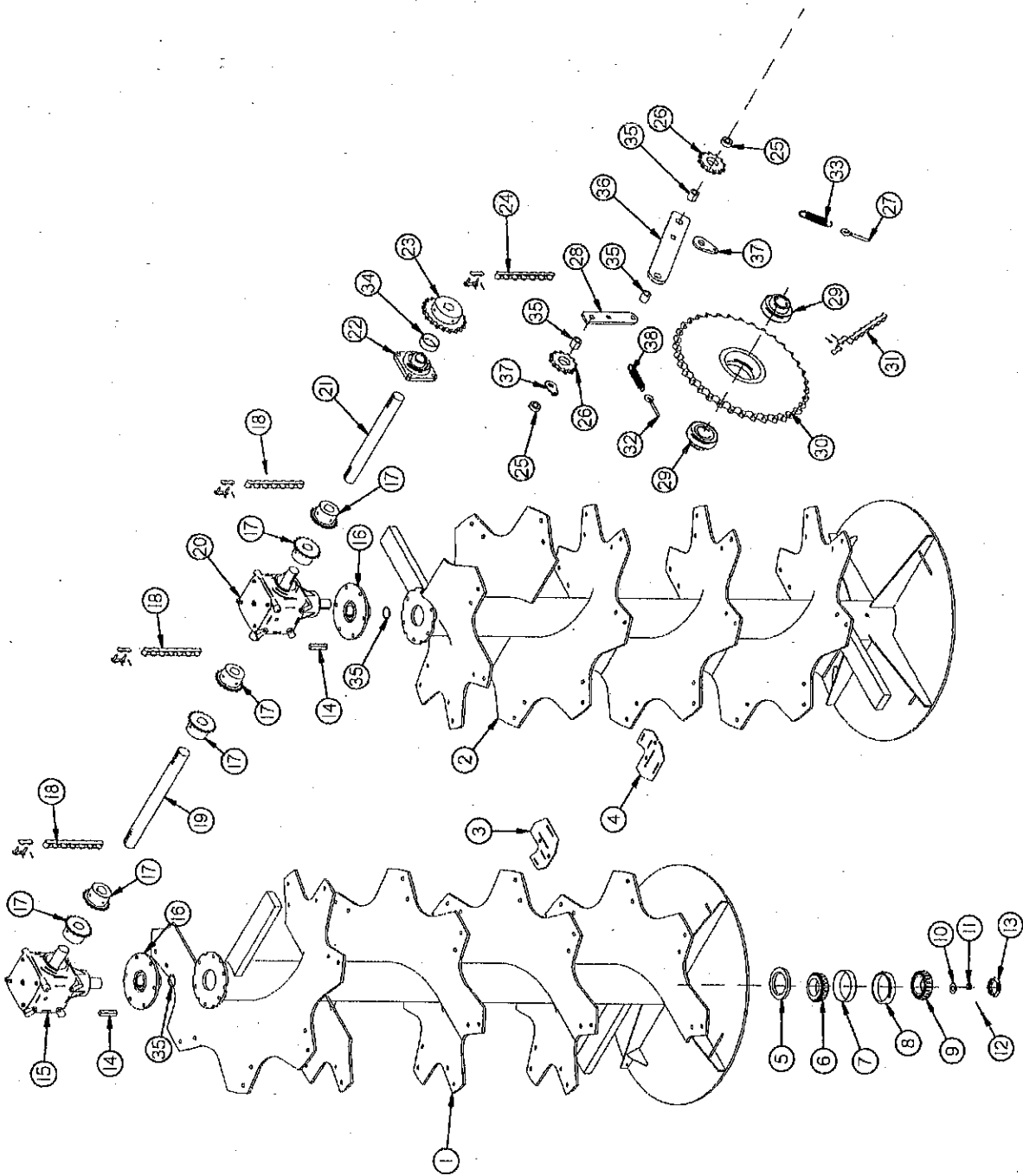

**FIGURE 9**  
**H&S HP425VB & HP550VB SPREADERS**  
**VERTICAL BEATERS FRAME ASSEMBLY**

<b>ITEM</b>	<b>HP425VB</b>	<b>HP550VB</b>	<b>DESCRIPTION</b>
1.	HGV1	HGV2	Frame
2.	HGV3	HGV4	Rear Shield
3.	HGV5	HGV6	Shield Filler
4.	HGV7	"	Cross Shaft Shield
5.	HGV8	"	Beater Bottom Mount
6.	HGV9	"	Pan Hinge
7.	HGV10	"	Leg
8.	HGV11	"	Pan Bottom
9.	HGV12	"	Pan
10.	K103	"	Spring
11.	HGV13	"	Pan Handle
12.	HGV14	"	Pan Handle Stop
13.	HGV15	"	Gearbox Bottom Shield
14.	HGV16	"	Gearbox Top Shield
15.	HGV17	"	Chain Damper
16.	S416	"	Manual Holder Clamp
17.	S414	"	Cap
18.	S415	"	Manual Holder Tube
19.	S418	"	Cap w/Hole
20.	HGV18	"	Sprocket Idler Shaft
21.	12V62	"	Snap Ring
22.	F69	"	Shield Bracket
23.	F56	"	Clip Pin
24.	42N105	"	Back Stake Filler
25.	X195	"	Pin
26.	X194	"	Latch Mounting Bracket
27.	X192	"	Latch (Rubber)
28.	X193	"	Latch Catch Bracket
29.	HGV48	"	5/16" x 1-1/2" Step Bolt
30.	HGV49	"	Stone Guard
31.	HGV50	"	Lifting Eye
32.	HGV51	"	Grease Line
33.	HGV52	"	Grease Fitting

**NOTE: " (MEANS SAME AS PREVIOUS MODEL)**

FIGURE 10

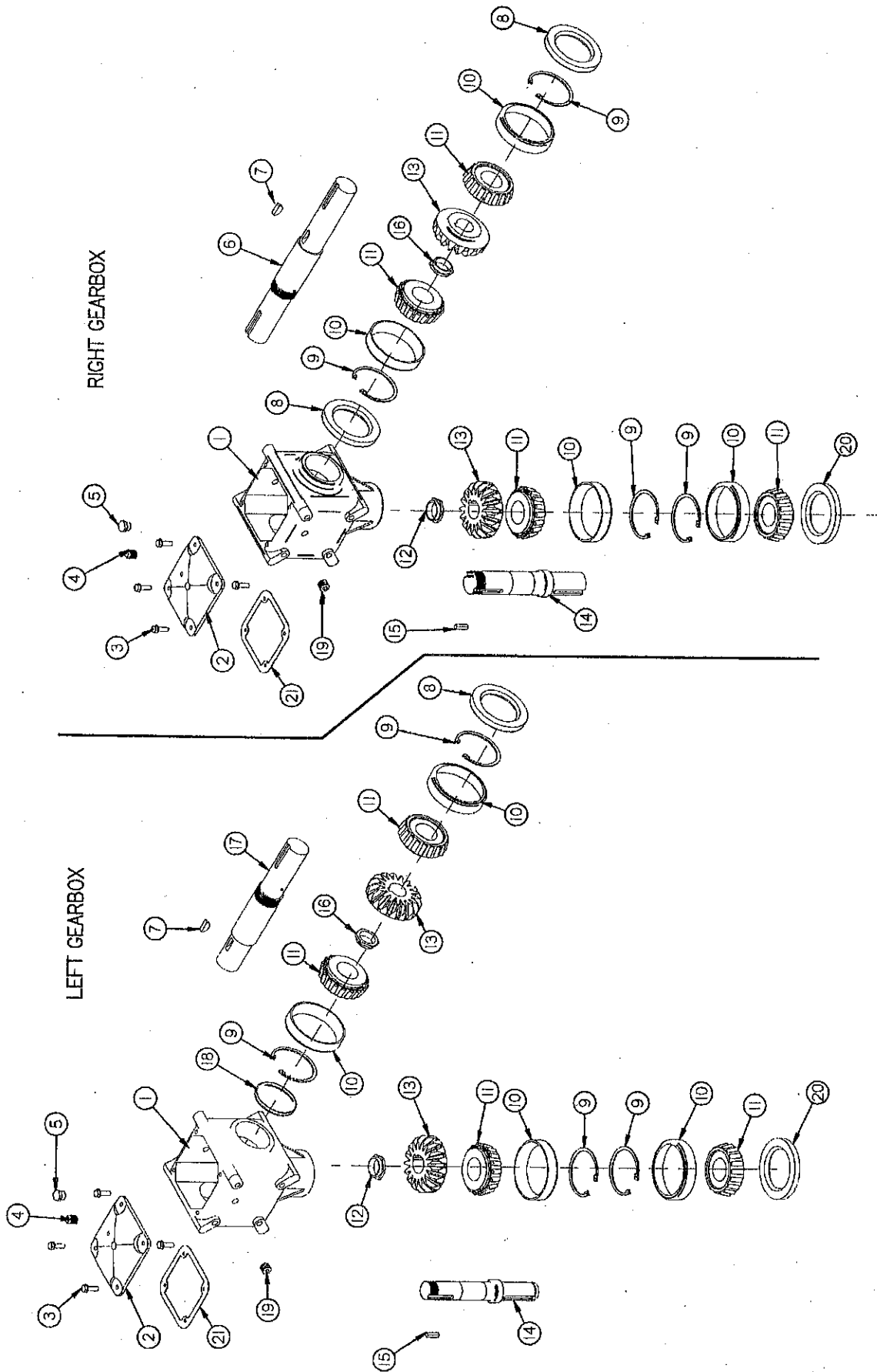

**FIGURE 10**  
**H&S HP425VB & HP550VB SPREADERS**  
**VERTICAL BEATERS DRIVE TRAIN**

ITEM	HP425VB	HP550VB	DESCRIPTION
1.	HGV19	HGV20	Beater Left Hand
2.	HGV21	HGV22	Beater Right Hand
3.	HGV23	"	Beater Blade Left
4.	HGV24	"	Beater Blade Right
5.	HGV27	"	Seal
6.	B5	"	Bearing Cone
7.	B5A	"	Bearing Cup
8.	3G18	"	Bearing Cup
9.	3G7	"	Bearing Cone
10.	BFR63	"	Washer
11.	BFR64	"	Nut
12.	BFR65	"	Cotter Pin
13.	17G144	"	Hub Cap
14.	S38	"	3/8" x 2-3/8" Square Key
15.	HGV28	"	Gearbox Left
16.	HGV29	"	Gearbox Connector
17.	42N25	"	Sprocket 50-B-20 1-3/4" Bore
18.	42N27	"	Connector Chain #50 x 20 Pitches
19.	HGV31	"	Gearbox Cross Shaft
20.	HGV32	"	Gearbox Right
21.	HGV33	"	Gearbox Drive Shaft
22.	HGV41	"	Bearing
23.	HGV25	"	Sprocket 80-B-20 1-3/4" Bore
24.	-	HGV34	Gearbox Chain #80 x 136 Pitches
25.	HGV35	-	Gearbox Chain #80 x 97 Pitches
*	12V52	"	Bearing
26.	12V77	"	Idler Sprocket w/Bearing (80-A-12)
27.	HGV47	"	I-Bolt 5/16" x 3"
28.	HGV36	"	Beater Tightener
29.	42N100	"	Bearing
30.	HGV37	-	Sprocket 80-A-36 to 80-A-20
*	-	HGV38	Sprocket 80-A-20 to 80-A-20
31.	-	HGV39	Drive Chain #80 x 117 Pitches
*	HGV40	-	Drive Chain #80 x 109 Pitches
32.	HGV46	"	I-Bolt 5/16" x 1"
33.	10R14	"	Spring
34.	HGV30	"	Spacer
35.	HGV43	"	Spacer
36.	HGV42	"	Tightener
37.	56N160	"	Spring Holder
38.	ST36	"	Spring

**NOTE: \* (MEANS NOT SHOWN)**  
**" (MEANS SAME AS PREVIOUS MODEL)**  
**- (MEANS NOT USED ON THIS MODEL)**

FIGURE 11



**FIGURE 11**  
**H&S HP425VB & HP550VB SPREADERS**  
**VERTICAL BEATERS BEVEL GEARBOX**

<b>ITEM</b>	<b>HP425VB</b>	<b>HP550VB</b>	<b>DESCRIPTION</b>
1.	G125	"	Gearbox Housing
2.	G126	"	Cover
3.	G56	"	Capscrew
4.	G65	"	Plug 3/8" NPT
5.	G144	"	Vent 1/8" NPT
6.	HGV26	"	Input Shaft
7.	G61	"	Woodruff Key (Hard "E" 1210)
8.	G136	"	Seal
9.	G130	"	Snap Ring
*	G141	"	Shim
10.	G128	"	Bearing Cup #14276
11.	G129	"	Bearing Cone #14137A
12.	G133	"	Strake Nut 1-3/4"
13.	G147	"	Bevel Gear
14.	HGV44	"	Output Shaft
15.	G139	"	Key 3/8" Square x 1-3/8" Hardened
16.	G132	"	Stake Nut 2"
17.	HGV45	"	Input Shaft
18.	G140	"	Cap
19.	G65	"	Plug 3/8" x 18 NPT
20.	G136	"	Seal
21.	G138	"	Gasket
*	HGV28	"	Gearbox Left Complete
*	HGV32	"	Gearbox Right Complete

**NOTE: \* (MEANS SOT SHOWN)**

**" (MEANS SAME AS PREVIOUS MODEL)**

FIGURE 12

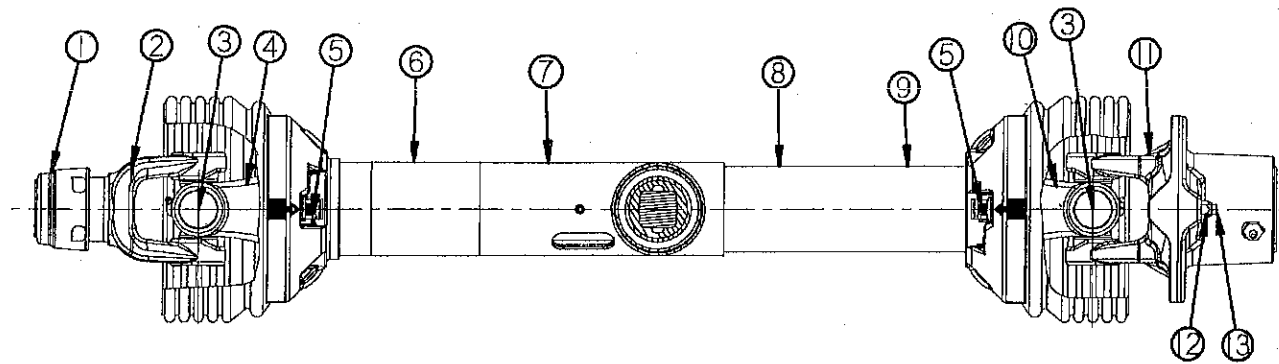

FIGURE 12  
H&S HP425 & HP550 SPREADERS  
PTO & OVERRUNNING CLUTCH

ITEM	540 RPM	1000 RPM 1-3/8"	1000 RPM 1-3/4"	DESCRIPTION
1.	16SV274	"	16SV275	Auto-Lock Repair Kit
2.	42N115	55N68	55N69	Auto-Lock Yoke Assembly
3.	16SV179	"	"	35R Cross Bearing Kit
4.	42N116	"	"	Yoke Shaft
5.	16SV181	"	"	Nylon Repair Kit
6.	16SV283	"	"	Safety Sign
7.	42N117	"	"	Outer Guard
8.	42N118	"	"	Inner Guard
9.	16SV286	"	"	Safety Sign
10.	42N119	"	"	Yoke, Tube & Slip Sleeve
11.	42N120	"	"	OR Ball Shear Assembly
12.	16SV193	"	"	5/16"-18 Lock Nut
13.	42N121	-	-	5/16"-18 x 2" Bolt GR. 8 (540 RPM)
*	-	55N71	"	5/16"-18 x 2" Bolt GR. 5 (1000 RPM)
*	42N122	55N72	55N73	Joint & Shaft Half Assembly w/Guard
*	42N123	55N74	55N75	Joint & Shaft Half Assembly
*	42N124	55N76	"	Joint & Tube Half Assembly w/Guard
*	42N125	55N77	"	Joint & Tube Half Assembly
*	42N126	55N78	55N79	Complete PTO
*	S204	"	"	PTO Safety Manual

NOTE: \* (MEANS NOT SHOWN)  
 - (MEANS NOT USED ON THIS MODEL)  
 " (MEANS SAME AS PREVIOUS PART NO.)

FIGURE 13

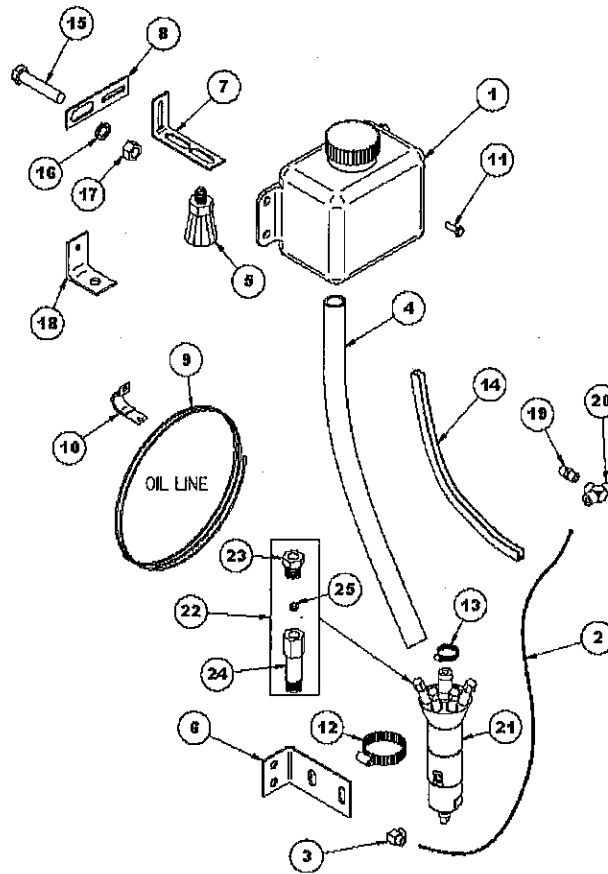

FIGURE 13  
H&S HP425 & HP550 SPREADERS  
CHAIN OILER

ITEM	PART#	DESCRIPTION	ITEM	PART#	DESCRIPTION
1.	HGV63	Reservoir	14.	HGV77	Edging 12"
2.	HGV64	Hydraulic Hose 1/4" x 80"	*	HGV78	Large Tube Holder
3.	HGV65	O-Ring/JIC Elbow	15.	HGV79	9/16" x 2-1/2" Bolt GR. 5
4.	HGV66	Filler Hose	16.	HGV80	9/16" Lockwasher
5.	HGV67	Brush	17.	HGV81	9/16" Nut
6.	HGV68	Pump Mount Bracket	18.	ST33	Angle
7.	HGV69	Brush Bracket	19.	BFR188	3/8" Nipple Nut
8.	HGV70	Bracket Mount	20.	BFR74	3/8" Tee
9.	HGV71	Oiler Tube 5/32" (50')	21.	HGV82	Complete Pump
10.	HGV72	Small Tube Holder	*	HGV83	Pump Repair Kit
11.	HGV73	3/16" x 3/8" Tap Tight	22.	HGV84	Manifold Assembly (Complete)
12.	HGV74	2" Hose Clamp	23.	HGV85	Sleeve Nut
13.	HGV75	1" Hose Clamp	24.	HGV86	Standoff
*	HGV76	Medium Tube Holder	25.	HGV87	Ferrule
			*	HGV62	Complete Oiler Kit

NOTE: \* (MEANS NOT SHOWN)

FIGURE 14

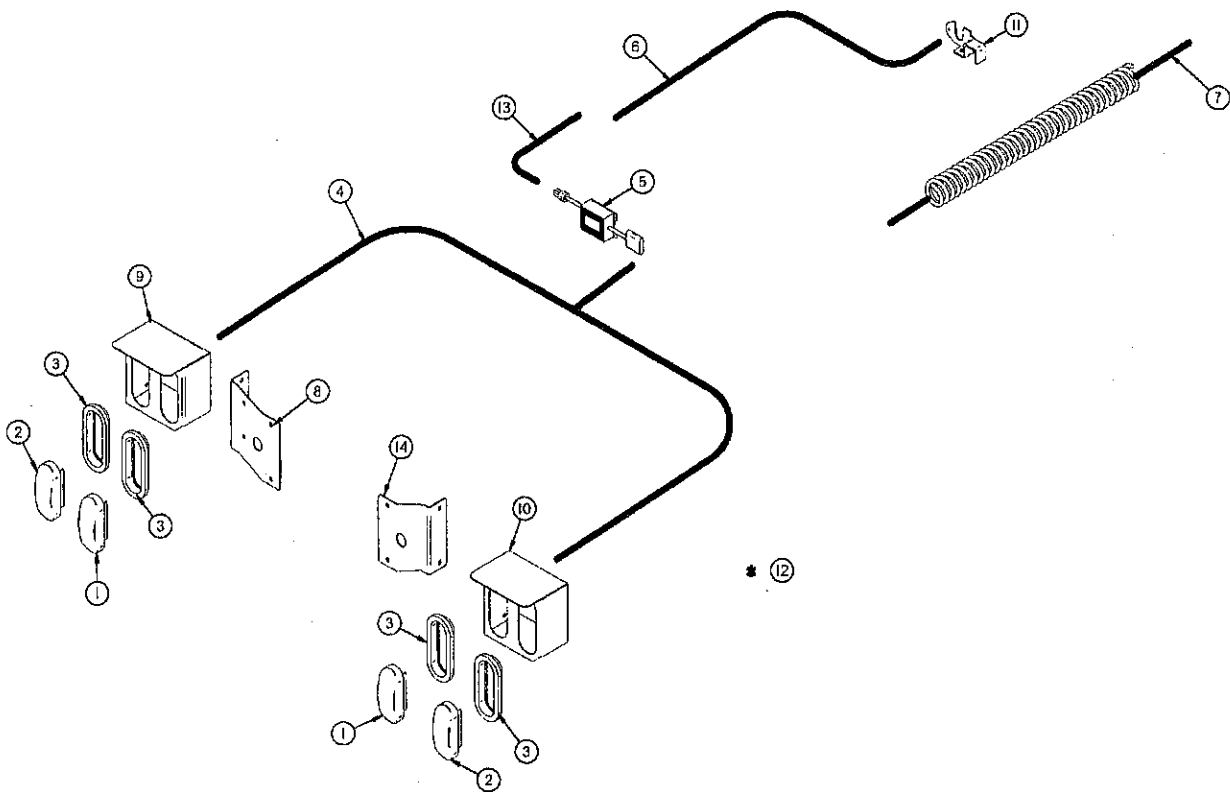

FIGURE 14  
H&S HP425 & HP550 SPRADERS  
OPTIONAL LIGHTING

ITEM	HP425	HP550	DESCRIPTION
1.	S310	"	Red Tail Light
2.	S309	"	Yellow Hazard Light
3.	S308	"	Rubber Light Mount
4.	56N155	"	Tail Light Loom
5.	S441	"	Light Module
6.	56N154	"	Flasher Module Loom
7.	S317	"	Tractor Cord
8.	55N60	"	Light Bracket Mount Left
9.	55N61	"	Light Bracket Left
10.	55N62	"	Light Bracket Right
11.	55N63	"	Light Plug Bracket
12.	55N64	"	Metal Cushioned Cable Clamps
13.	BFR666	"	Extension Light Harness
14.	55N80	"	Light Bracket Mount Right

NOTE: " (MEANS SAME AS PREVIOUS PART NO.)



FIGURE 15

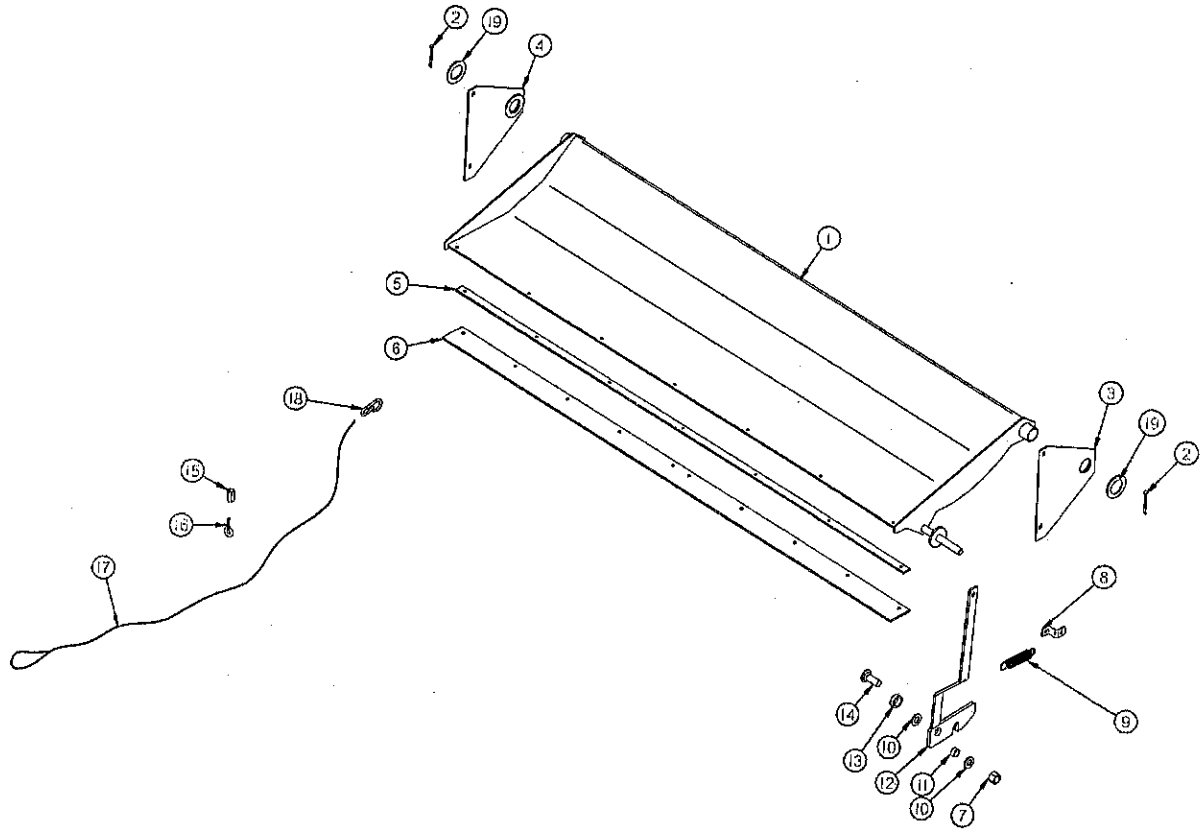

FIGURE 15  
H&S HP425 & HP550 SPREADERS  
OPTIONAL REAR PAN

ITEM	HP425	HP550	DESCRIPTION
1.	42N127	"	Pan
2.	R70	"	3/16" x 2" Cotter Pin
3.	42N128	"	Pan Plate Left
4.	42N129	"	Pan Plate Right
5.	42N130	"	Pan Strap
6.	42N131	"	Rubber
7.	HE7	"	3/4" Lock Nut
8.	F69	"	Bracket
9.	ST36	"	Spring
10.	T73	"	Washer
11.	42N132	"	Latch Bushing
12.	42N133	"	Latch
13.	42N134	"	Latch Spacer
14.	42N135	"	3/4" x 2-1/2" Carriage Bolt GR. 5
15.	23N212	"	3/8" Long Nut
16.	23N213	"	3/8" x 1" I-Bolt
17.	42N136	"	Rope (18')
18.	BFR295	"	Snap Hook
19.	56N170	"	Pan Washer

NOTE: " (MEANS SAME AS PREVIOUS PART NO.)

